

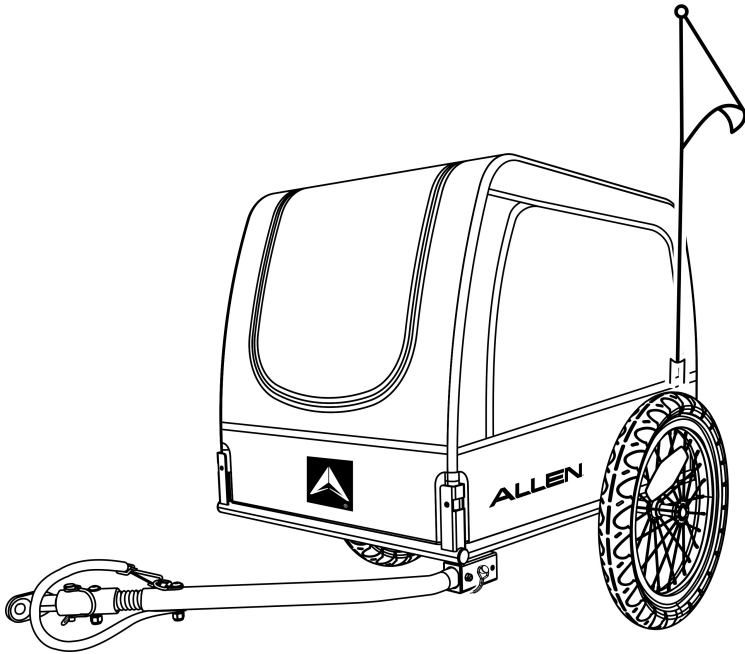

Dog Trailer – Model ADT2
Owner's Manual & Safety Instructions



Important:
Keep these instructions for future reference

I. Choose the right size of trailer

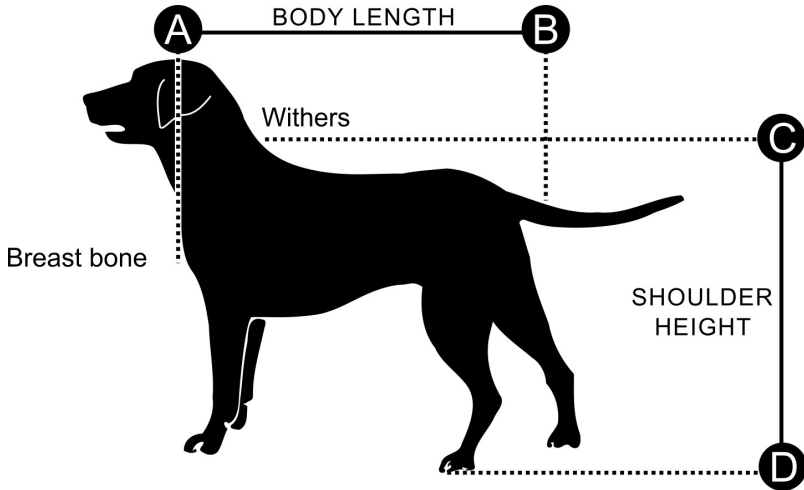

Trailer Size	Large
Max. Body Length	30 in. (76 cm)
Max. Shoulder Height	21 in. (54 cm)
Max. Weight	66 lbs. (30 kg)

II. Safety Guidelines

⚠️ WARNING

Do read instructions before driving. Failure to comply with the instructions and warnings in this manual could result in serious injury or death.

- Consult veterinarian to ensure it is safe for your pet to ride in a trailer.
- Make sure pet cannot make contact with the wheel spokes.
- Check comfort and safety of pet frequently, especially during hot or cold weather.
- Never leave pet unattended and **ALWAYS HOLD THE TRAILER/STROLLER FROM TIPPING BACKWARD WHEN DOG IS ENTERING OR LEAVING THE TRAILER.**
- DO NOT use with a total load that exceeds 66 lbs. (30kg).
- This product is not suitable for running or skating.
- Never use pet trailer for transporting child or cargo.

- DO NOT make any modifications to the product. Any parcels placed on the trailer may cause the trailer to become unstable.
- Accessories which are not approved by the manufacturer shall not be used.
- Only use replacement parts supplied or recommended by the manufacturer.
- DO NOT over-inflate the tires. Failure to comply with the rated pressure on the tire sidewall may lead to explosion of the tire and possible injury.
- Before each ride, be sure the trailer does not interfere with braking, pedaling or steering of the bicycle.
- Always comply with local regulations when using the trailer on public roadways.
- Never ride a bicycle at night without adequate lighting. Obey all local legal requirements for lighting.
- When using your trailer, you are towing extra weight and a bigger vehicle. You must allow more time for braking, slowing, stopping and starting, and allow more room for turns and passageways. Experiment with the loaded trailer in an uncongested area until you become familiar with how your bike handles towing a trailer.
- Avoid rocks, curbs, hard braking and sudden swerving. Avoid riding over obstacles with one wheel, as this may cause the trailer to tip over.
- Always ride with the front and rear door fully closed to protect pet from flying debris and prevent pet from jumping from the trailer
- The rider of the bicycle must be at least 16 years old.
- Recommended speed limits: - 10 mph (16 km/h) on smooth, straight roads – 5 mph (8 km/h) when turning or on uneven roads.
- Trailer weight must be properly distributed for safe handling. The weight on the hitch connector should be between 30 N (\approx 6.6 lbs. or 3 kg) and 80 N (\approx 17.6 lbs. or 8 kg). To measure this, load your trailer and place next to bathroom scale. Step on scale and make a note of your weight. Standing on scale, lift up the end of the tow bar one foot (approximately 25cm) off the ground. If the weight is too low, the rear wheel of the bicycle could lose traction. If it is too high the hitch may be overloaded.

⚠️ WARNING

Never overload the trailer and never ride with a tow bar load that is outside the specified range of 6.6 to 17.6 lbs. (3 – 8 kg). Always distribute the load evenly. Failure to do so could result in accidents with serious injury or death.

Tip: Make sure that your dog is positioned with its center of gravity as close as possible to the wheel axle. This is the best way to ride with an optimal weight distribution.

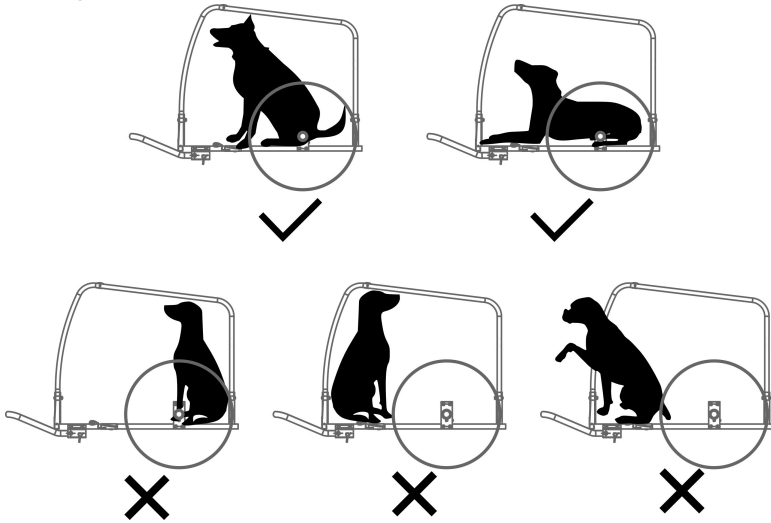

III. Box Contents

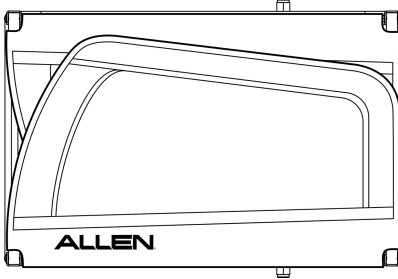
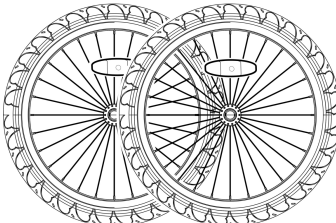
	
1 x Main frame	2 x Wheels

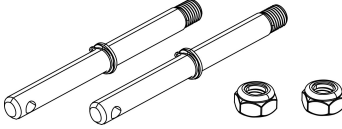
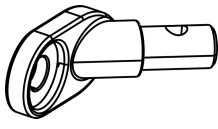
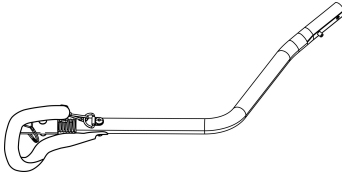
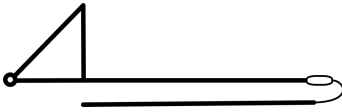
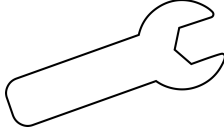
	
<p>2 x Wheel axle</p>	<p>1 x Universal hitch</p>
	
<p>1 x Tow bar</p>	<p>1 x Flag</p>
<p style="text-align: center;">Tool</p>	
	
<p style="text-align: center;">19mm Wrench</p>	

IV. Opening the Main Frame

Take out the trailer main frame and all other components from the carton. Remove black protective caps on 4 corners. Raise both side panels to an upright position (Figure 1).

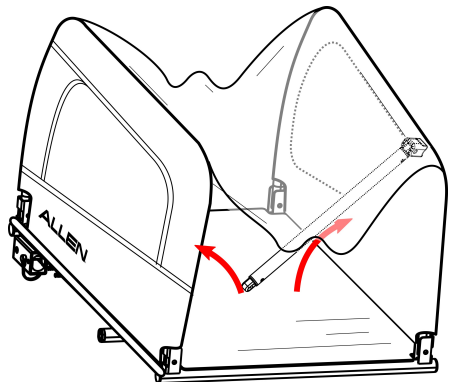

Figure 1

Fasten the crossbar to the top part of the main frame. Raise and lock the cross bar using the safety pin attached to the bolt (Figure 2). Make sure that safety pins are properly locked in place as shown (Figure 3).

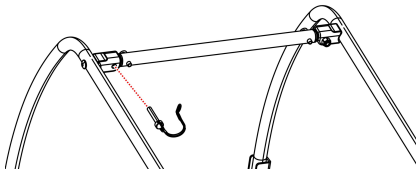
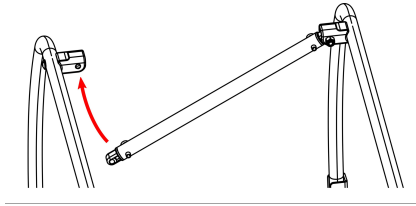

Figure 2

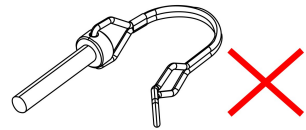
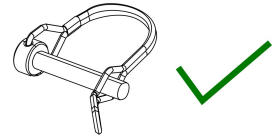

Figure 3

V. Attaching the Wheels

Insert wheel axle into axle receiver underneath the trailer frame and lock the safety pin (Figure 4). Put the wheel and the screw nut on the axle (Figure 5). Fasten the screw nut with 19mm wrench (Figure 6).

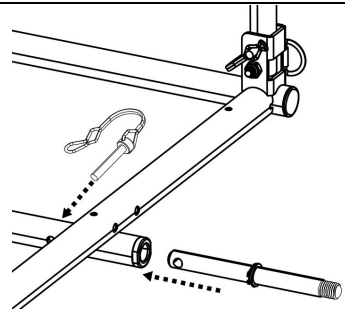

Figure 4

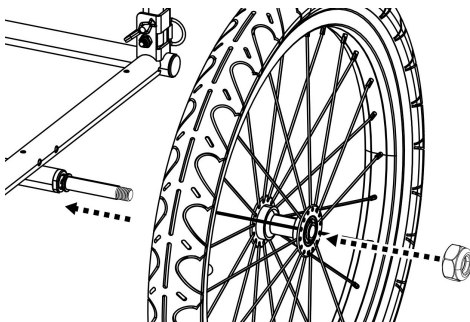

Figure 5

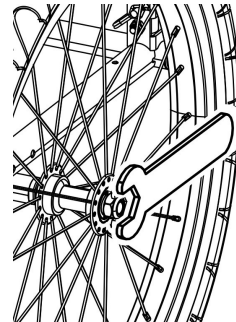

Figure 6

VI. Attaching the Flag

Insert the flag pole into the flagpole pocket at the left rear corner of the side panel (Figure 7, Figure 8).

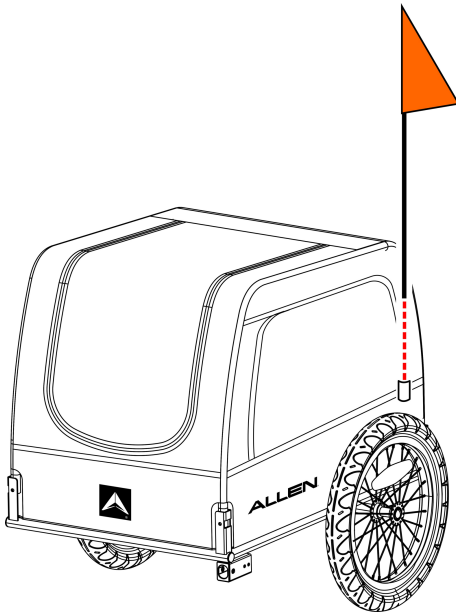

Figure 7

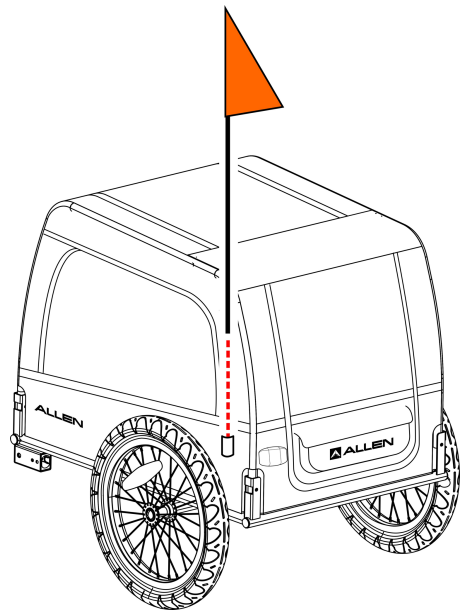

Figure 8

VII. Installing the Tow Bar

Pressing the spring button, slide the tow bar into the tow bar receiver until the spring button comes out of the hole A. Insert the safety pin from the hole B through the other side. Make sure the safety pin is properly locked in place (Figure 9).

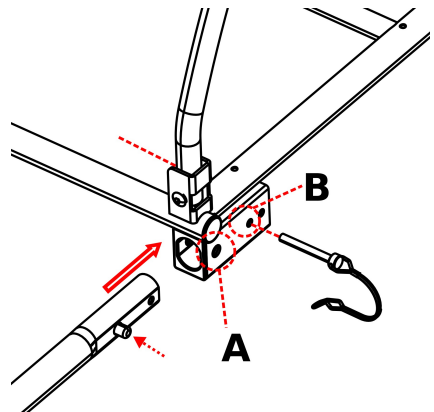

Figure 9

VIII. Attaching Trailer to Bicycle

1. Quick release Axle: Remove the quick release from the left side of bike' s rear axle. Install the hitch between the quick release and frame. Tighten the quick release following the bike manufacturer' s manual. Hitch can remain on the bike when the trailer is removed (Figure 10).

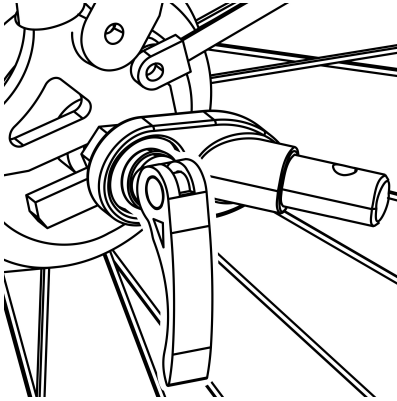

Figure 10

⚠ WARNING

The tension-adjusting nut must engage the threads for at least five full turns in order to ensure adequate clamping force for holding the rear wheel securely. Failure to tighten the tension-adjusting nut fully may result in accidents with serious injury or death. If the quick release skewer is too short, it must be replaced. Consult a professional bicycle mechanic for the appropriate parts and assistance.

2. Nutted Axle: Unscrew the nut with washer from the left side of bike' s rear axle. Install the hitch onto the axle and screw the nut back on with the washer(Figure 11).

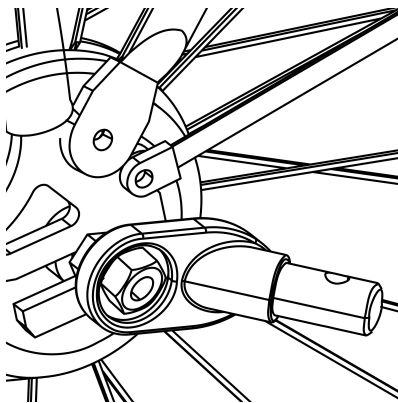

Figure 11

⚠ WARNING

The axle nut must engage the threads for at least five full turns in order to ensure adequate clamping force for holding the rear wheel securely. Failure to tighten the nut fully may result in accidents with serious injury or death. If the axle is too short, the Universal Hitch cannot be used! Consult a professional bicycle mechanic for the appropriate parts and assistance.

3. Thru Axle: The universal hitch doesn't fit a bike with thru axle. Please consult the retailer for possible solution.

Connect the coupler on the tow bar and secure the safety pin (Figure 12). Once the tow bar is attached, wrap safety belt around the frame of the bike and hook onto the D-ring on the tow bar.

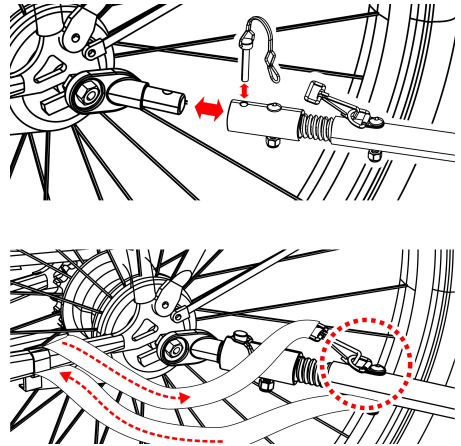

Figure 12

IX. Before You Ride:

Check before each use:

1. Wheels are properly secured to the trailer
2. Tires are inflated to recommended pressure on the tire side wall
3. Tow bar is properly secured to the trailer
4. Hitch is properly secured to the bicycle
5. All safety pins are securely locked in place.
6. Safety strap on the tow bar is properly installed
7. Weight of tow bar at coupler is greater than 6.6 lbs. (3 kg) but does not exceed 17.6 lbs. (8 kg) with fully loaded trailer
8. Make sure that bicycle is in proper working order, especially brakes and tires (refer to bicycle manufacturer's instructions)
9. Safety flag is in place
10. Always leash your dog/pet in the trailer.

X. Maintenance and Care

Storage: For longer product life, store trailer indoors. The trailer should not be stored at temperatures less than -10°F (-23°C) or greater than 150°F (65°C).

Fabric Care: Hand wash fabric parts with warm water and mild soap. DO NOT use bleach or solvents. Wipe dry and store out of direct sunlight in a dry, well-ventilated area. Clean windows with a damp, soft cloth.

XI. Warranty

- This product has a limited lifetime warranty. Please consult <https://allen.bike/pages/bike-rack-trailer-warranty> for more details.
- Claims can only be submitted together with the dated proof of purchase.
- The warranty does not cover natural wear and damage due to excess strain or damage due to misuse.



www.Allen.Bike

CUSTOMERSERVICE@ALLEN.BIKE

USA Office:

505 Beachland Blvd.

Suite 1-1002

Vero Beach, FL 32963