

**WARNING:** Bikes or rack falling in road can cause serious accidents resulting in bodily injury—do not use rack on any vehicle on which it can not be properly mounted as described in this instruction sheet.

- Rack must be completely set up to safely transport bicycles.
- Top hooks must be completely hooked over solid metal edges at top/ front of trunk lid or rear door—never hook to rain gutters, roof racks, vertical glass, rubber or plastic moldings.
- Never use on front of vehicle. Mount rack only with bottom foot on a rigid surface of car (never on glass), and with bottom foot fully extended.
- Max capacity of rack is 2 Bicycles (**MAX CAPACITY: 70 LB**) - no tandems, mopeds, or recumbents.
- Bikes must be securely tied to rack. Use bike tie-downs, or additional straps if necessary.
- Car tail lights must remain visible. Drive conservatively, especially over bumps. Never use off-road. Remove rack from vehicle when not in use.
- Do not use if any part of the rack is damaged, worn, or missing. Contact R. A. Allen Co., Inc. for replacement parts.

**CAUTION:** Use Allen MT2 only in accordance with local motor vehicle and traffic regulations.

- To avoid damage to rear door or trunk, do not open trunk or rear door when hooks or rack are in place.
- Install rack and load bicycles only at a safe distance away from moving traffic.
- Only rubber feet and rack should come into contact with car.
- Make sure that all of rack and bicycles are kept at a safe distance from road and hot exhaust.
- Remove rack from car when not in use

## A. SETTING UP RACK:

**NOTE: TO RETURN RACK TO FOLDED POSITION, REVERSE STEPS BELOW.**

1. START WITH RACK IN A FOLDED POSITION

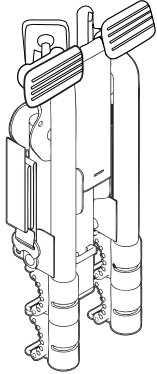

2. ROTATE TIE-DOWNS, AND FULLY EXTEND BOTTOM FOOT

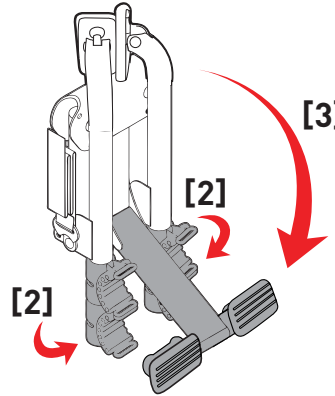

4. ROTATE BOTH TOP FEET DOWN BY 90 DEGREES TO OPEN, FULLY ENGAGING PINS

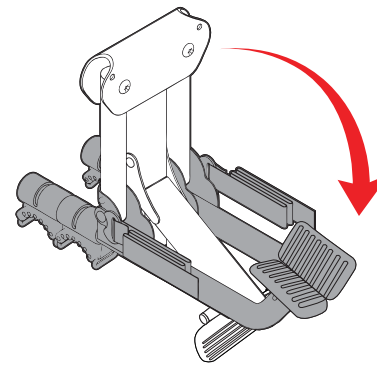

5. ROTATE CARRY ARMS INTO AN UPRIGHT POSITION, FULLY ENGAGING POP-UP PINS

6. RELEASE POP-UP PINS ON FRONT FEET AND EXTEND CARRY ARMS, MAKING CERTAIN THAT POP-UP PINS FULLY ENGAGE WHEN ARMS ARE IN EXTENDED POSITION.

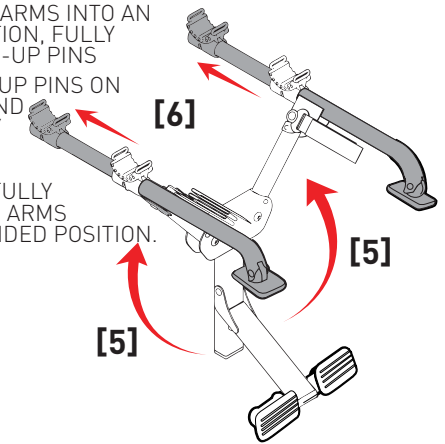

## B. BEFORE INSTALLING RACK:

1. MAKE SURE THAT CONTACT SURFACES BETWEEN CAR AND RUBBER FEET ARE THOROUGHLY CLEAN AND FREE OF DIRT. RACK PADS WILL PICK UP DIRT AND SAND IF PLACED ON THE GROUND BEFORE INSTALLATION.
2. MAKE SURE THAT ALL BUCKLES ARE THREADED AS SHOWN ON RIGHT.
3. TIE A HALF-HITCH KNOT BELOW BUCKLE FOR SAFETY ONCE TOP STRAP LENGTH IS SET
4. INSPECT ALL STRAPS TO MAKE SURE THAT THEY ARE NOT WORN OR DAMAGED IN ANY WAY.

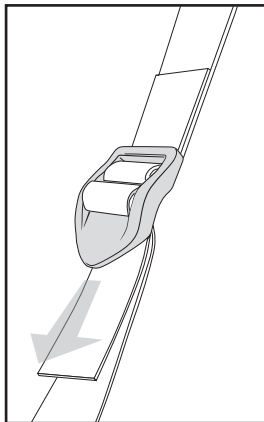

## C. INSTALLING RACK ON VEHICLE:

1. TOP HOOKS MUST BE COMPLETELY HOOKED OVER METAL EDGES AT TOP OF TRUNK, REAR DOOR, OR HATCHBACK. NEVER HOOK TO RAIN GUTTERS, ROOF RACKS, VERTICAL GLASS OR PLASTIC MOLDINGS. OPEN TRUNK/ HATCH SLIGHTLY FOR EASIEST ATTACHMENT OF HOOKS. MAKE SURE THAT HOOKS DO NOT BIND WHEN TRUNK/ HATCH IS OPENED. BINDING HOOKS WILL DAMAGE VEHICLE.
2. SET LENGTH OF TOP STRAPS TO POSITION RACK WITH ITS CARRY ARMS INCLINED SLIGHTLY UPWARDS, AND HIGH ENOUGH TO KEEP BIKES AWAY FROM ROAD AND EXHAUST.
3. ONCE THE LENGTH OF THE TOP STRAPS ARE SET, THE BOTTOM FOOT ASSEMBLY SHOULD BE HELD AGAINST THE VEHICLE IN ITS COMPLETELY OPEN POSITION. IT IS IMPORTANT THAT THE BOTTOM RUBBER PADS ARE INSTALLED ON THE VEHICLE IN A LOCATION WHERE THERE IS PROPER SUPPORT. THE BOTTOM FEET SHOULD NEVER BE INSTALLED ON GLASS.
4. COMPLETELY HOOK BOTTOM HOOKS TO A METAL EDGE BELOW BUMPER, OR AT THE BOTTOM OF THE TRUNK/ REAR DOOR. IF THERE IS NO METAL EDGE BELOW BUMPER, SEE ALTERNATE METHOD FOR BOTTOM HOOK ATTACHMENT ON THE NEXT PAGE.
5. COMPLETELY TIGHTEN BOTTOM STRAPS BY PULLING ON FREE END OF STRAP UNTIL ELASTIC PORTION OF STRAP IS FULLY STRETCHED.
6. ONCE THE BOTTOM STRAP IS IN PLACE, YOU SHOULD INSTALL THE LEFT AND RIGHT SIDE STRAPS. FIRST IT IS IMPORTANT TO MAKE SURE THAT YOU USE THE CORRECT STRAPS FOR THIS - THE SIDE STRAPS ARE THE STRAPS WITH THE SMALL METAL HOOKS THAT ARE LABELED "SIDE STRAPS". THE HOOKS ON THESE STRAPS SHOULD BE ATTACHED TO THE LEFT AND RIGHT SIDE OF THE TRUNK/ REAR DOOR. ONCE THE HOOKS ARE IN PLACE, COMPLETELY TIGHTEN THE STRAPS BY PULLING ON THE FREE END OF THE STRAPS.

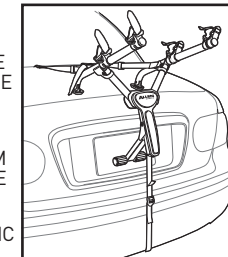

MT2 on SEDAN

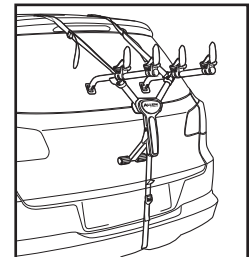

MT2 on SUV

SECURING TOP HOOKS ON VEHICLES WITHOUT ADEQUATE CLEARANCE AT THE TOP EDGE OF REAR TRUNK/ HATCH: CAREFULLY PLACE TOP HOOKS INSIDE OF VEHICLE (JUST INSIDE OF TOP EDGE OF REAR TRUNK/ HATCH). CAREFULLY CLOSE REAR TRUNK/ HATCH ON TOP STRAPS EXTENDING FROM TOP HOOKS, MAKING CERTAIN THAT HOOKS OR BUCKLES DO NOT BIND BETWEEN FRAME AND REAR DOOR. IMPORTANT: WITH REAR DOOR CLOSED, PULL TOP STRAPS TO BRING HOOKS TIGHT AGAINST INSIDE OF VEHICLE. RE-THREAD TOP STRAPS AS SHOWN IN SECTION B AND MOUNT RACK ON VEHICLE.

