

**WARNING:** Bikes or rack falling in road can cause serious accidents resulting in bodily injury—do not use rack on any vehicle on which it can not be properly mounted as described in this instruction sheet.

- Rack should only be used on vehicles with a Class III or IV 2" receiver hitches.
- **NEVER** use on trailer or front of vehicles.
- Bikes must be tied to rack using tie-downs, or additional straps if necessary.
- Check periodically during use that all bolts and pins are tight, and that rack and bicycles are secure.
- Never carry more than 2 bicycles (**MAX CAPACITY: 140 LB**) - no tandems, mopeds, or recumbents. Car tail lights must remain visible. Bikes must be securely tied to rack. Use bike tie-downs, or additional straps if necessary.
- Drive conservatively, especially over bumps. Never use off-road.
- Do not use if any part of the rack is damaged, worn, or missing. Contact R. A. Allen Co., Inc. for replacement parts.

**CAUTION:** Use Allen QR520-EB only in accordance with local motor vehicle and traffic regulations.

- Install rack and load bicycles only at a safe distance away from moving traffic.
- Make sure that all of rack and bicycles are kept at a safe distance from road and hot exhaust.
- Only operate vehicle with rack in an upright, locked position.
- Bicycles should never extend beyond sides of vehicle.
- Remove rack from car, or fold carry arms down when not in use.

## A. PARTS

QR520-EB BOX SHOULD CONTAIN THE FOLLOWING ITEMS:

1-HITCH INSERT

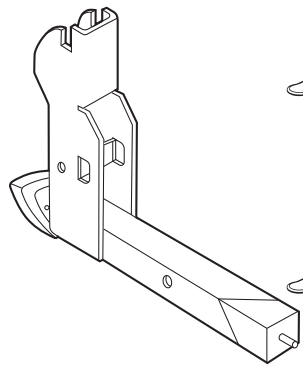

1-CARRY ARM ASSEMBLY

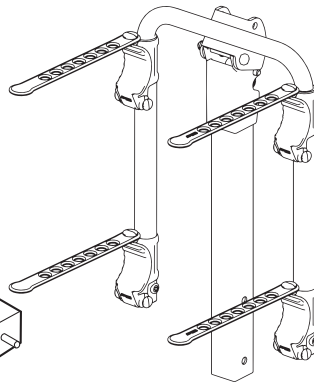

1-RR POST

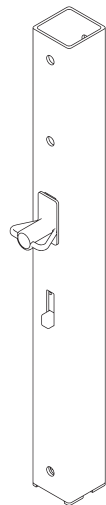

1- SPINE SHIELD

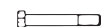

1—HARDWARE KIT, CONTAINING:

 2 - 3/8" X 2 1/2" BOLT

 1 - 3/8" X 3" BOLT

 3 - 3/8" LOCK NUT

 1 - KEYCHAIN

 2 - KEYS

 1 - 70" SURE STRAP

## B. ASSEMBLING RACK:

### STEP 1

- INSERT LOWER PORTION OF RR POST INTO HITCH INSERT SO THAT THE HOLES AT THE BOTTOM OF EACH PART LINE UP.
- INSERT THE 3/8" X 3" BOLT THROUGH THE HOLE, AND THREAD 1—3/8" LOCK NUT ONTO THE END OF THE BOLT.
- PIVOT THE RR POST INTO THE UPRIGHT POSITION, SO THAT THE SECURING LATCH SNAPS INTO PLACE.
- TIGHTEN NUT AND BOLT FIRMLY USING TWO WRENCHES.

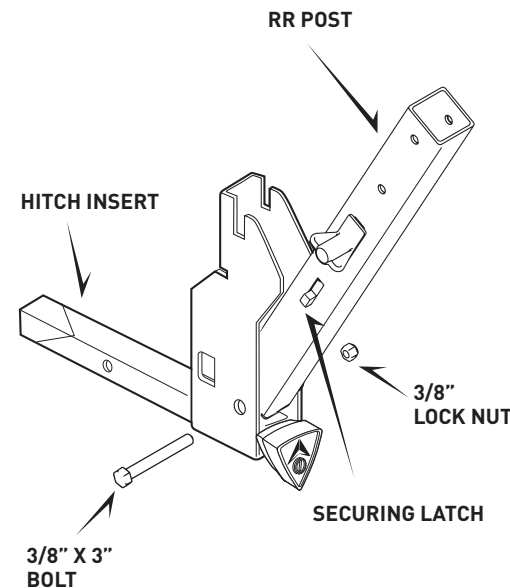

**TOOLS REQUIRED:** 2—9/16" WRENCH & 2—3/4" WRENCH; or 2 ADJUSTABLE WRENCHES

### STEP 2

- INSERT CARRY ARM ASSEMBLY INTO UPPER PORTION OF RR POST, LINING UP THE HOLES IN EACH PART.
  - INSERT THE 3/8" X 2 1/2" BOLTS THROUGH EACH HOLE, AND THREAD 1—3/8" LOCK NUT ONTO THE END OF THE BOLTS.
  - TIGHTEN EACH NUT AND BOLT FIRMLY USING TWO WRENCHES.
- NOTE:** UPON COMPLETION, BOTH PARTS SHOULD BE FIRMLY JOINED TOGETHER.

CARRY ARM ASSEMBLY

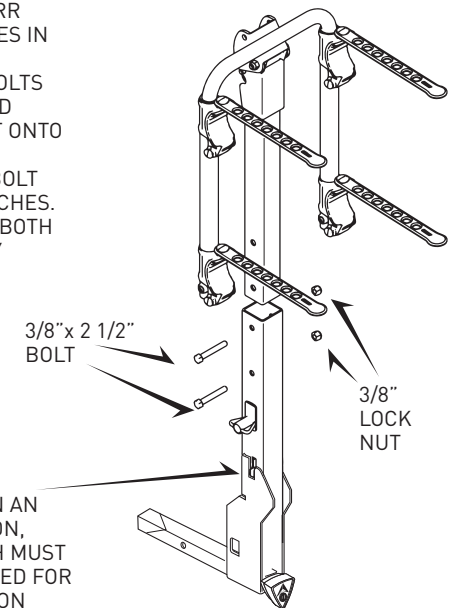

**IMPORTANT:**

WHEN RACK IS IN AN UPRIGHT POSITION, SECURING LATCH MUST BE FULLY ENGAGED FOR RACK TO FUNCTION PROPERLY.

### STEP 3

#### INSTALLING SPINE PAD

WITH "ALLEN SPORTS" IN THE UPPER POSITION, LINE UP THE RECESSES FOR THE NUT AND BOLT HEADS, AND SNAP THE SPINE PAD INTO PLACE ONTO THE RECEIVER RACK'S VERTICAL POST.

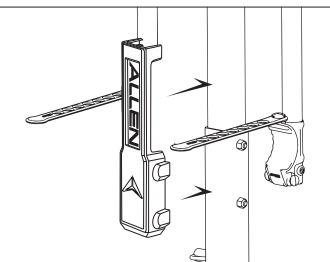

### C. INSTALLING RACK ONTO VEHICLE:

**THIS RACK SHOULD ONLY BE USED ON CLASS III OR IV 2" RECEIVER HITCHES PROFESSIONALLY INSTALLED ON AUTOMOBILES. NEVER USE THIS RACK ON A TRAILER OF ANY KIND.**

**STEP 1:** INSERT KEY INTO LOCK AND TURN KEY COUNTER-CLOCKWISE SO THAT LOCKING KNOB CAN TIGHTEN/ LOOSEN THE HITCH INSERT WEDGE.

**ROTATE KEY TO LOCK/ UNLOCK KNOB**

**CLOCKWISE TO LOCK  
COUNTER CLOCKWISE  
TO UNLOCK**



**STEP 2:** ROTATE LOCKING KNOB COUNTER CLOCKWISE TO LOOSEN THE HITCH INSERT WEDGE.

**ROTATE KNOB  
COUNTER CLOCKWISE  
TO LOOSEN HITCH WEDGE**



**STEP 3:** DEPRESS HITCH SPRING PIN AND INSERT RACK INTO RECEIVER HITCH UNTIL HITCH SPRING PIN ENGAGES HOLE IN VEHICLE RECEIVER HITCH

**STEP 4:** TURN THE LOCKING KNOB CLOCKWISE TO TIGHTEN THE RACK INSIDE OF THE RECEIVER HITCH. BE CAREFUL NOT TO OVER TIGHTEN; A PROPERLY SECURED RACK SHOULD BE FREE OF ANY MOVEMENT INSIDE OF THE RECEIVER HITCH.

**HITCH  
INSERT WEDGE**

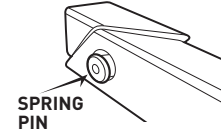

**STEP 5 (OPTIONAL):** INSERT KEY AND ROTATE CLOCKWISE TO THAT LOCKING KNOB CAN SPIN FREELY. THIS WILL LOCK YOUR RACK TO YOUR VEHICLE. TO REMOVE RACK FROM VEHICLE, FOLLOW STEPS 1 THROUGH 3 ABOVE.

**SPRING  
PIN**

### D. FOLDING UP CARRY ARMS:

- TO FOLD UP CARRY ARMS, SQUEEZE TOGETHER THE TWO RED TABS ON THE BACK OF THE CARRY ARM ASSEMBLY, AND SWING CARRY ARMS INTO UPRIGHT POSITION.
- THE PINS CONNECTED TO THESE TABS SHOULD "SNAP" INTO PLACE TO HOLD THE CARRY ARMS IN AN UPRIGHT POSITION.
- REVERSING THIS PROCESS WILL KEEP THE CARRY ARMS LOCKED IN A DOWN POSITION.
- IF BOTH PINS ON YOUR RACK DO NOT PROPERLY ENGAGE THE CARRY ARMS IN THE UPRIGHT POSITION, DO NOT USE YOUR RACK, AND CONTACT R. A. ALLEN CO..

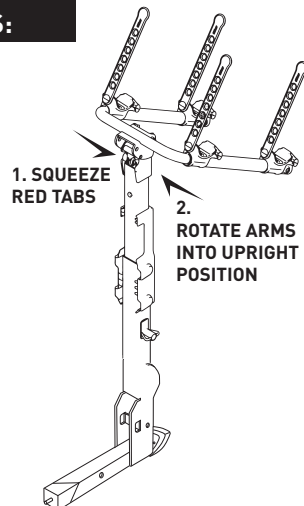

### E. LOADING BICYCLES ON RACK:

REMOVE ALL LOOSE ITEMS FROM BICYCLES (PUMPS, BAGS, ETC.), AND CHECK THAT ALL QUICK RELEASE HUBS ARE TIGHT. LOAD FIRST BICYCLE WITH ITS CHAIN AND GEARS FACING AWAY FROM RACK. MAKE SURE THAT BICYCLES DO NOT COME IN CONTACT WITH VEHICLE.

LOAD SUBSEQUENT BICYCLES IN ALTERNATING DIRECTIONS. FOR BEST WEIGHT DISTRIBUTION, LOAD HEAVIEST BICYCLES FIRST, WITH LIGHTER BICYCLES ON THE OUTSIDE. ADD PADDING BETWEEN BICYCLE CONTACT POINTS, IF NECESSARY.

AFTER BICYCLES ARE LOADED, CHECK THAT ENTIRE RACK IS SECURE AND TIGHT, AND THAT THE RACK IS STILL FIRMLY IN PLACE. VISION OUT OF REAR WINDOW MAY BE RESTRICTED—USE SIDE MIRRORS ACCORDINGLY WHEN BACKING UP.

#### SPECIAL NOTE ON INSTALLING WOMEN'S STYLE FRAMES:

PLACE ONE CARRY ARM UNDER FRONT TOP TUBE. WITH THE OTHER CARRY ARM, ROTATE TIE-DOWN CRADLE, AND PLACE CARRY IN SPACE BEHIND SEAT TUBE AND BELOW REAR DOWN-STAY. THE **ALLEN 900B ADAPTOR BAR** IS ALSO RECOMMENDED FOR THIS APPLICATION.

### F. SECURING BIKES TO RACK:

ALL BIKES MUST BE SECURELY TIED TO RACK. USE INDIVIDUAL TIE-DOWN STRAPS, OR ADDITIONAL STRAPS IF NECESSARY.

1. PLACE BICYCLE IN CRADLE.

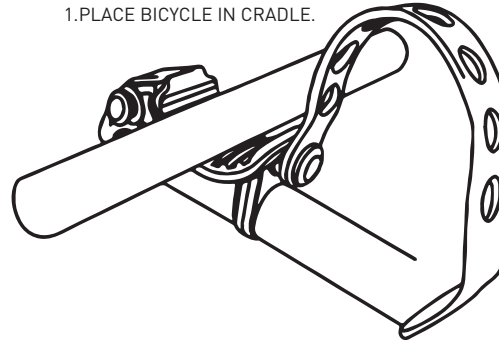

2. LOCK DOWN TIE-DOWN STRAP.

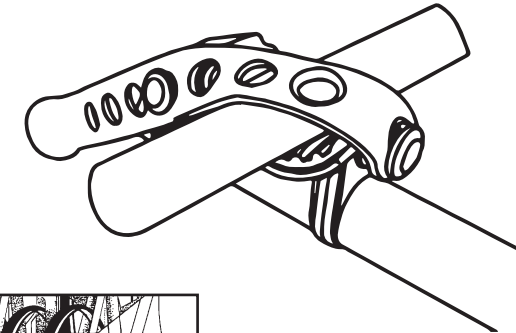

3. USE 70" STRAP TO PULL ALL BICYCLES TOGETHER AROUND BOTTOM BRACKETS. STRAP SHOULD ALSO SECURE WHEELS.

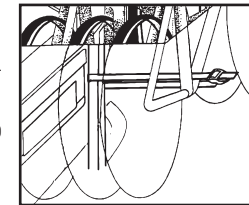

### ALLEN LIFETIME WARRANTY:

IF AN ALLEN BIKE RACK IS FOUND TO HAVE A DEFECT IN WORKMANSHIP OR MATERIAL OVER THE LIFETIME OF THE ORIGINAL PURCHASER, ALLEN WILL REPAIR OR REPLACE THE RACK FREE OF CHARGE. THE WARRANTY DOES NOT COVER DAMAGE OR WEAR WHICH OCCURS AS A RESULT OF DAY TO DAY USE OR GENERAL WEAR AND TEAR.



# ALLEN SPORTS

R. A. ALLEN CO., INC.—ALLEN SPORTS USA  
505 BEACHLAND BLVD.  
SUITE 1 - #1002  
VERO BEACH, FL 32963, USA  
CUSTOMERSERVICE@ALLEN.BIKE



For More  
Product Info &  
List of Dealers  
Scan Our QR Code

Get the latest news, info,  
give-a-ways and pics on  
our social media sites!



/AllenSportsGlobal



@GoAllenGlobal



@Allen.Global

WWW.ALLEN.BIKE

©2022 R. A. ALLEN CO., INC., ALL RIGHTS RESERVED V.3.22